

Hydraulic Pump Tester

Portable Hydraulic System Diagnostic Tool



The Tester displays the flow rate of a hydraulic pump at various pressures. The difference of the flow at no pressure and at an elevated pressure establishes the volumetric efficiency of the hydraulic pump. The pump efficiency helps to determine the condition of the pump.

Features:

- 3000 PSI Pressure Rating
- 0 – 30 Gallon Per Minute Flow Rating
- Needle Valve To Back-Pressure Component
- 0 – 5000 PSI Pressure Gauge
- Built In Relief Valve For Safety
- Cartridge Valve Construction For Easy Repair

The Tester can also be used to determine Hydraulic System flow rates and Relief Valve pressure settings.

Conveniently Test Hydraulic Systems In The Shop Or Field!

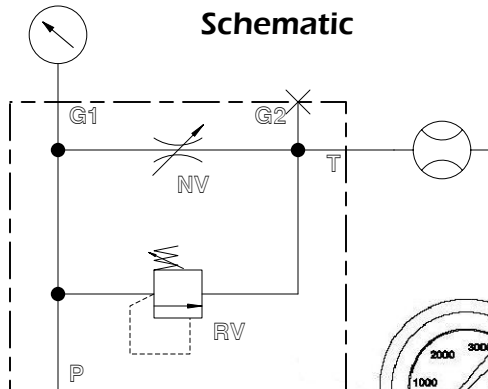
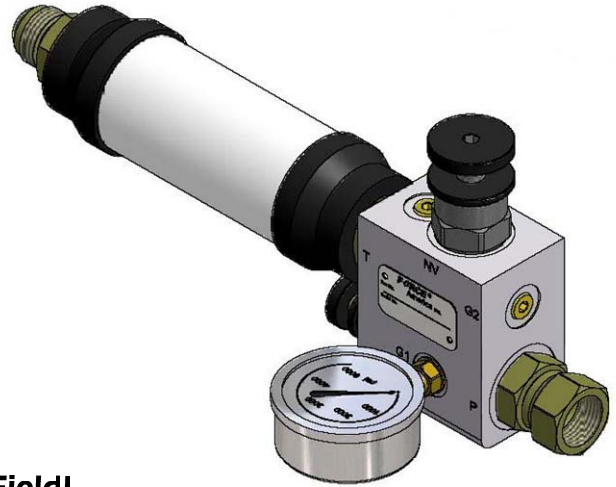

Dimensions

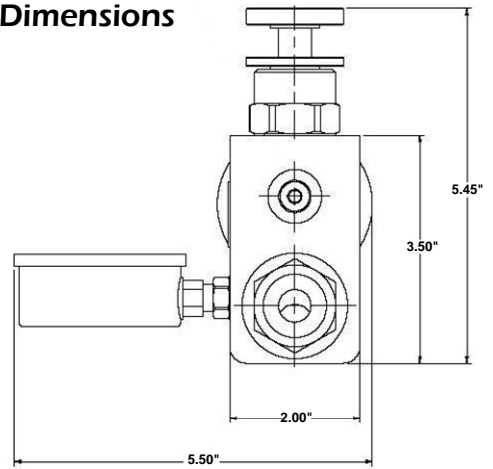

#12 JIC
Female Swivel

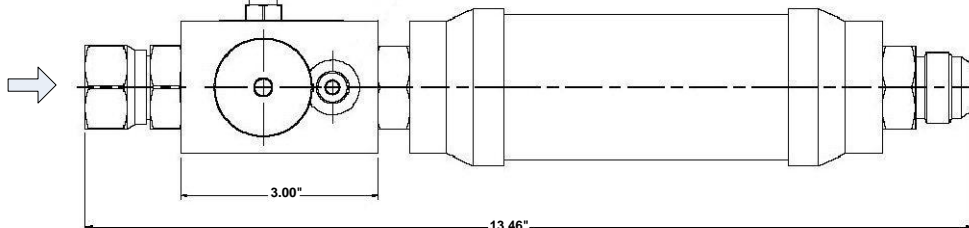

#12 JIC
Male

Part # C10260



1-888-99FORCE

www.forceamerica.com