



Auger Sensor

FB-360

F E A T U R E S

Rugged, heavy-duty shaft encoder for spreader auger and conveyer shafts. Sealed to IP68 and built to withstand harsh environments.

- Rugged, hard-anodized cast aluminum housing. Proven to resist salt corrosion.
- Dual, pre-loaded bearings provide a durable, long-life connection to Coupler and auger shaft.
- 360-pulse/revolution optical sensor - no need for multipliers.
- Integrated drive tang - can't be lost or misplaced
- IP68 rated connector and cordset - seals out water and contaminants.
- Higher pulse/revolution offers increased spreader control stability for slow-turning conveyers or large diameter augers.
- 3 Year Warranty



1-888-99FORCE

www.forceamerica.com

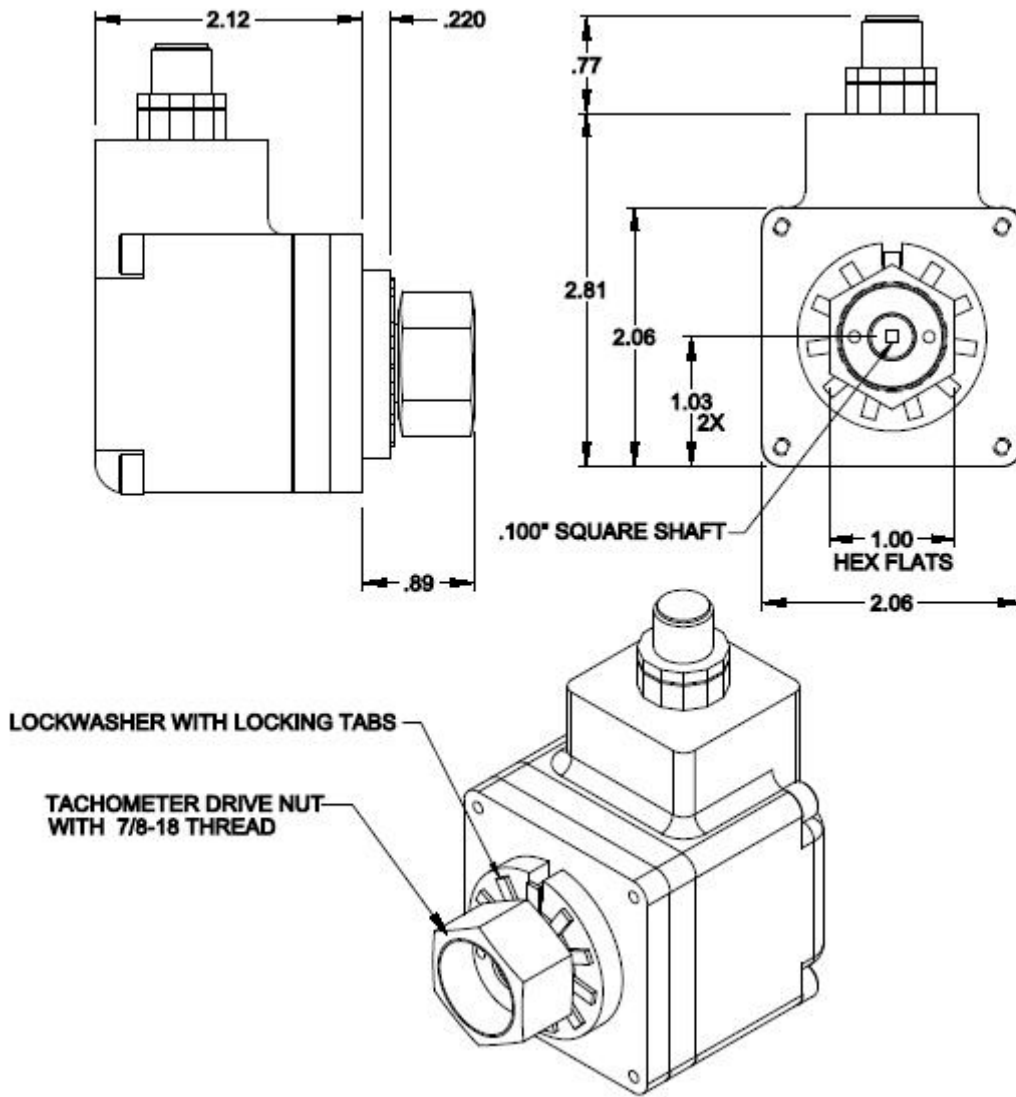

Specifications:

CONNECTOR PIN OUT:

| PIN..... | FUNCTION |
|----------|----------|
| 1..... | Vcc |
| 2..... | SIGNAL B |
| 3..... | GROUND |
| 4..... | SIGNAL A |
| 5..... | N/C |

Mating Connectors sold separately.

ELECTRICAL:

| | |
|---------------------------|------------------------------------|
| SUPPLY VOLTAGE (Vcc)..... | +5 to +28VDC |
| CURRENT REQUIREMENTS..... | 50mA MAX. (NO LOAD CONDITION) |
| OUTPUT FORMAT..... | SINGLE CHANNEL OUTPUT |
| RESOLUTION..... | 360 PULSES/REV |
| OUTPUT CIRCUIT..... | 2N2222 W/ 1kΩ PULL-UP |
| WAVEFORM DUTY CYCLE..... | 50% +/-5% (FIXED & NON-ADJUSTABLE) |

ENVIRONMENTAL:

| | |
|---------------------------------|---|
| OPERATION AND STORAGE TEMP..... | -40°C TO +80°C. |
| HUMIDITY..... | 100% |
| SHOCK..... | 50G's, 11mSEC DURATION |
| VIBRATION..... | 5-2000 Hz @ 20G's |
| SHAFT LOADING..... | 100lbs. AXIAL and RADIAL |
| SEALING..... | UNIT SEALED AGAINST OIL, CUTTING FLUIDS AND WATER |
| ENCLOSURE RATINGS..... | IP68 when connected |