

F E A T U R E S

Individual compensators for the ADD-A-FOLD make it possible to have independent simultaneous control.

The compensator will help control flow on one function despite changing pressures on another.

- New urethane seals
 - Eliminates the need for back-up rings
 - More durable than standard o-rings
- Eliminated the screw adjustment
 - A seldom used feature that was a potential leak point
- Thicker spool cage
 - Improved durability
- Improved load sense pickup
 - 360° pickup



Size 12



Size 10

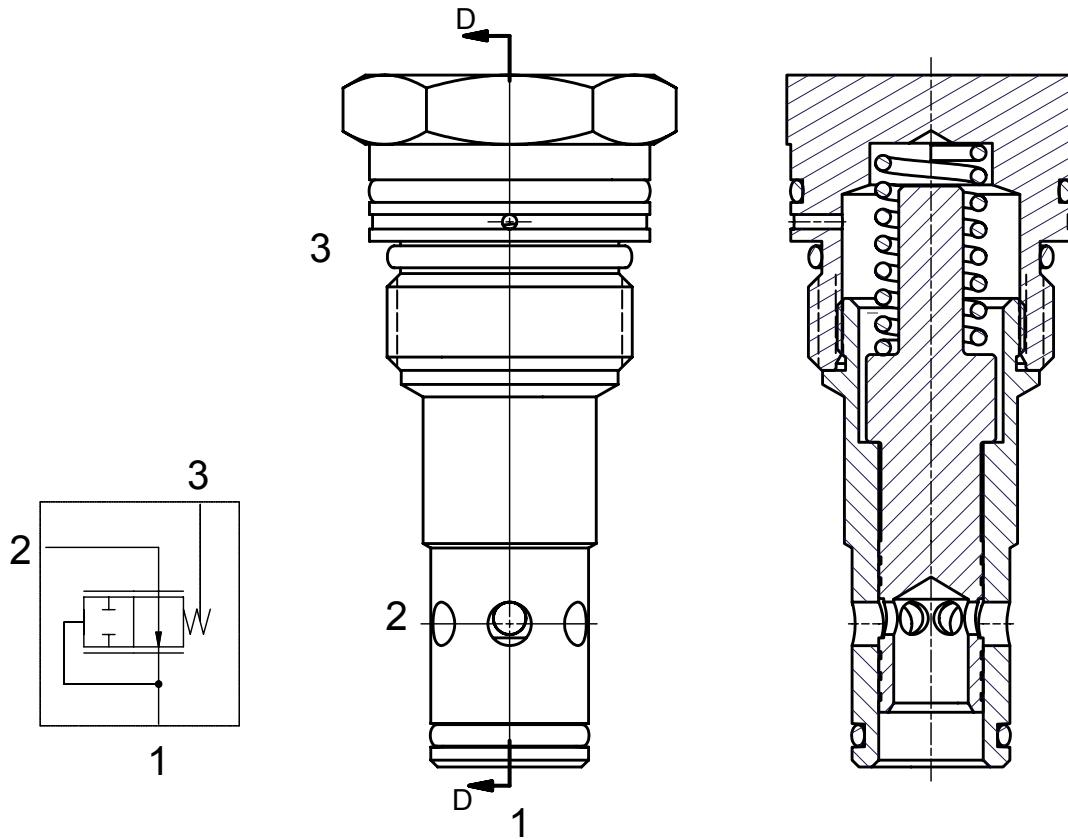

Cartridge	C10442-10	C10442-15	C10463-15
Replaces	75151-01P	75151-03P	75151-23P
Body	Size 10	Size 10	Size 12
Operating ΔP	100 PSI	150 PSI	150 PSI
PSI Rating	3500 PSI	3500 PSI	3500 PSI
Torque spec	40-45 ft-lbs	40-45 ft-lbs	50-52 ft-lbs
Seal kit	SK-C10442	SK-C10442	SK-C10463



501 East Cliff Road
Burnsville, MN 55337
1-888-99FORCE
www.forceamerica.com

© 2010 FORCE America, Inc.
Part Number: FA900

Service Centers and Sales

Bismarck, ND	800-624-7568	Fort Dodge, IA	800-362-2994
Charlotte, NC	800-788-8598	Kansas City, MO	800-383-4724
Chicago, IL	800-433-5765	Milwaukee, WI	800-722-5844
Columbus, OH	888-449-0356	Minneapolis, MN	800-328-2732
Dallas, TX	800-893-7225	Philadelphia, PA	800-492-6621
Denver, CO	888-833-7711	Salt Lake City, UT	877-230-0505